

ALPHA 725 MK2

Shaker system



MB DYNAMICS
Sound & Vibration Testing Technology

Quiet electrodynamic 700N shaker for Squeak & Rattle testing, vibration testing and modal analysis

Excitation forces of 700N Sine Peak or 500N Random RMS, the robust and low-maintenance design and the low operating noise enable the ALPHA 725 MK2 shaker to be used universally for Squeak & Rattle tests on small and medium-sized components, vibration tests and modal analysis. The integrated temperature-controlled quiet fan, pneumatic load support for centering the moving element in zero position independent of the applied payload and extensive safety and monitoring functions ensure reliable and safe continuous operation. Naturally, the ALPHA 725 MK2 meets the strict requirements of GMW 14011, BMW PR311 and TPJLR.00.187 as well as other Squeak & Rattle test specifications for the maximum permissible operating noise of the shaker used. The high efficiency and the low weight of only 26kg allow mobile use of ALPHA shakers for structural and modal analysis. The monitoring of the shakers and the control of the associated power amplifier is done conveniently and easily from the central test bench computer via a supplied control application.



Figure 1: ALPHA 725 MK2 front & rear

Features & Benefits:

- Lightweight (26kg only!) and transportable
- Compact design, easy integration into a wide range of test benches
- Robust design, low maintenance, reliable and durable
- Extremely quiet, ideal for Squeak & Rattle
- Max. force: 700N Sine Peak
- Max. displacement: 25mm pk-pk
- Frequency range: DC-3000Hz
- Frictionless guidance of the moving element
- Integrated pneumatic load support
- Integrated air spring for generating static preloads
- Integrated overtemperature protection
- Temperature-controlled quiet fan
- Remote control and monitoring via RS-485 network
- Optional water cooling enables noiseless cooling even with high excitation forces in continuous operation
- Low magnetic stray fields

Typical applications:

- Vibration test systems for excitation in 1 to 6 DOFs
- Squeak & Rattle testing on small and medium-sized components
- Material- and component testing
- Structural and modal analyses

Options / Accessories:

- Trunnion base for vertical and horizontal alignment
- Mounting tables in various sizes
- Horizontal moving tables
- Water cooling (retrofitable!)
- Climate-option for use within climate chamber in the temperature range from -40°C to +80°C

ALPHA 725 MK2

Shaker system



MB DYNAMICS
Sound & Vibration Testing Technology

Technical specifications:

ALPHA 725 MK2 vibration exciter	
Maximum dynamic force	
Sine	700N pk
Random	500N RMS
Time History	1400N pk, instantaneous peak
Maximum static force	1000N, continuous
Operating noise *	
Noise Rating Curve (NR)	NR16, typical
Sound pressure level **	<25dB(A)
Time Varying Loudness ***	<0,1 Sone
Maximum displacement	25mm pk-pk
Maximum velocity	1,5m/s
Frequency range	3Hz-3000Hz (optional DC-3000Hz)
Maximum payload vertical	90kg
Maximum payload horizontal	8kg
∅ Mounting table	198mm or 278mm, other sizes on request
Moving mass including 180mm ∅ mounting table / without mounting table	5,6kg / 3,8kg
Overtravel protection	Optional
Overtemperature protection	Yes, integrated temperature sensor, automatic activation of cooling and, if necessary, system shutdown in the event of further inadmissibly high heating
Integrated cooling	1 integrated, temperature-controlled quiet fan
Load support	Yes, manual adjustment using pressure control valve
Dimensions (∅ * height)	198mm ∅ * 465mm
Weight	26kg
Temperature range during operation, standard	+5°C to +40°C
Temperature range during operation, with optional climate package	-40°C to +80°C
Maximum coil current	10A RMS / 35A pk
Coil resistance	2*1,7 Ohm

- * Measured at 70cm from the shaker when excited with a typical Squeak & Rattle test profile in the frequency range from 5Hz to 100Hz with an averaged acceleration level of 0.3gRMS
- ** A-weighted Sound Pressure Level, FAST (125ms), 20Hz to 20kHz
- *** N10 Percentile Level, loudness according to DIN45631/A1, measured in accordance with GMW14011

Alternative shakers:

Type	Force, sine / noise	Vibration path	Frequency range
ALPHA 1025 MK2	1000N pk / 600N RMS	25mm pk-pk	DC-3000Hz
ALPHA 1525 MK2	1500N pk / 1000N RMS	25mm pk-pk	DC-3000Hz
ALPHA 2025 MK2	2000N pk / 1200N RMS	25mm pk-pk	DC-2000Hz
ALPHA 2050 MK2	2000N pk / 1200N RMS	50mm pk-pk	DC-1000Hz

ALPHA 725 MK2

Shaker system

MB A500 power amplifier

Our ALPHA 1025 MK2 and ALPHA 725 MK2 shakers are driven by the corresponding MB A500 power amplifier. The low background noise and the low harmonic distortion of the amplifier enable distortion-free excitation and minimize the operating noise of the ALPHA shakers. Extensive safety and monitoring functions prevent possible overloads and guarantee reliable and safe operation of power amplifiers and shakers. Three temperature-controlled fans on the front panel of the amplifier ensure cooling as required and minimize the operating noise of the amplifier. The activation of the amplifier and setting of the desired gain for up to 16 power amplifiers is carried out via an associated control app directly from the central test bench computer. The power supply of the MB A500 can be configured for mains voltages from 180VAC to 260VAC or 90VAC to 130VAC. A DC-coupled version of the MB A500 is also available on request for extremely low-frequency excitations.

Technical data:

MB A500 Power Amplifier	
Frequency range	0.2Hz-20kHz (DC coupled available on request)
Number of separate inputs	2
Number of separate outputs	2
Max. output power @20Ohm load	2000W
Max. short-time output current	50A pk , per channel
Max. short-time output voltage	85V pk, per channel
THD at 1kHz into 4 Ohm and -3dB	<1%
Signal Limiter	Yes
Monitoring max. output current	Yes
Operating temperature monitoring	Yes
Watchdog timer	Yes
Cooling	3 fans, speed temperature controlled
AC mains input	180VAC to 260VAC (high-line) or 90VAC to 130VAC (low line), fused with 16A
Dimensions (width*height*depth)	483mm*88mm*340mm
Weight	7kg (15.4lbs)



ALPHA 725 MK2

Shaker system



MB DYNAMICS
Sound & Vibration Testing Technology

Accessories / Options for ALPHA 725 MK2 vibration exciters

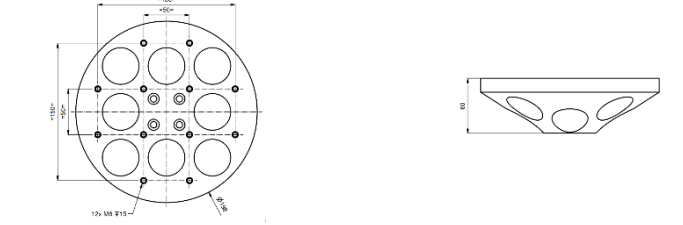
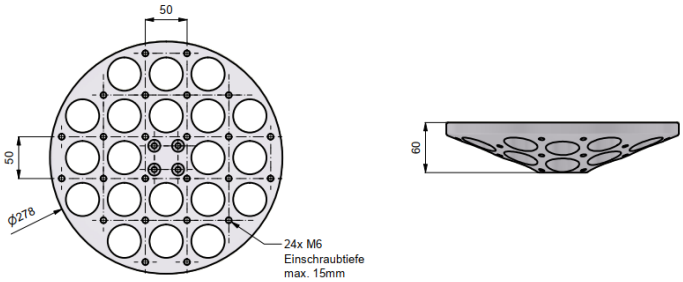
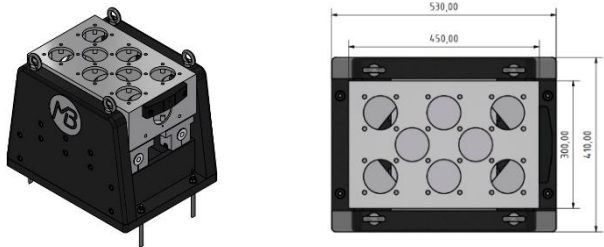
<p>Mounting table, 198mm diameter</p> <p>Diameter: 198mm M6x1 thread inserts on 50mm*50mm hole grid Weight: 1,8kg</p>	
<p>Mounting table, 278mm diameter</p> <p>Diameter: 278mm M6x1 threaded inserts on 50mm*50mm grid pattern Weight: 3,2kg</p>	
<p>Trunnion base</p> <p>Allows the shaker to rotate 90° from the vertical to the horizontal</p>	
<p>Horizontal moving table</p> <p>Magnesium mounting table Mounting surface of 300mm*450mm M6 threaded inserts on 50mm*50mm grid pattern Frictionless air bearing Moving mass of the table: approx. 10kg Maximum payload: 50kg Dimensions: 410mm*514mm*530mm Weight: 236kg</p>	
<p>Water cooling</p> <p>Enables silent cooling of the ALPHA 725 MK2 shaker even at high excitation forces in continuous operation. Water cooling is a prerequisite for the climate option. Includes air-cooled heat exchanger with a cooling capacity of approx. 1000Watt as well as 10m supply line and quick couplings.</p>	
<p>Climate option</p> <p>Enables the use of the ALPHA 725 MK2 shaker within a climatic chamber in the temperature range from -40°C to +80°C. Includes thermal insulation of the ALPHA 725 MK2 shaker and constant temperature control through an external combined heating/cooling unit.</p>	